



CHANTLAND

PVS

Material Handling Solutions

PORTA-VALVE VALVE BAGGER

MODEL 4200V

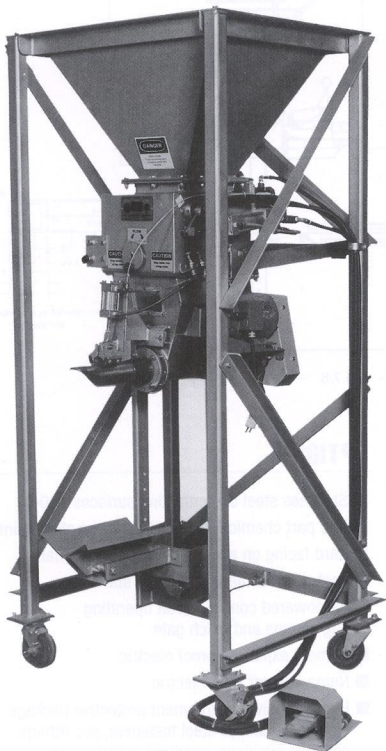

Hheavy duty gross weigh auger bagger for filling valve-type bags with dry flaked, powdered, pelleted, or granular materials.

DESIGN FEATURES:

- Accuracy of +/- 1/2 of 1% obtainable with good product flow and consistent bulk density.
- Speeds up to (4) 50# bags per minute.
- Versatile – 20 lb to 110 lb weight range.
- Available with #304 stainless steel on all contacting surfaces.
- Portable – easily relocates from one supply bin to another.
- Space saver feature with low head room.
- Easy installation and simple to operate.
- Easily converts to fill open-mouth bags.

SOLUTIONS

www.chantland.com

PACKERS • CONVEYORS • PALLETIZERS • SYSTEMS

PORTA-VALVE

VALVE BAGGER

MODEL 4200V

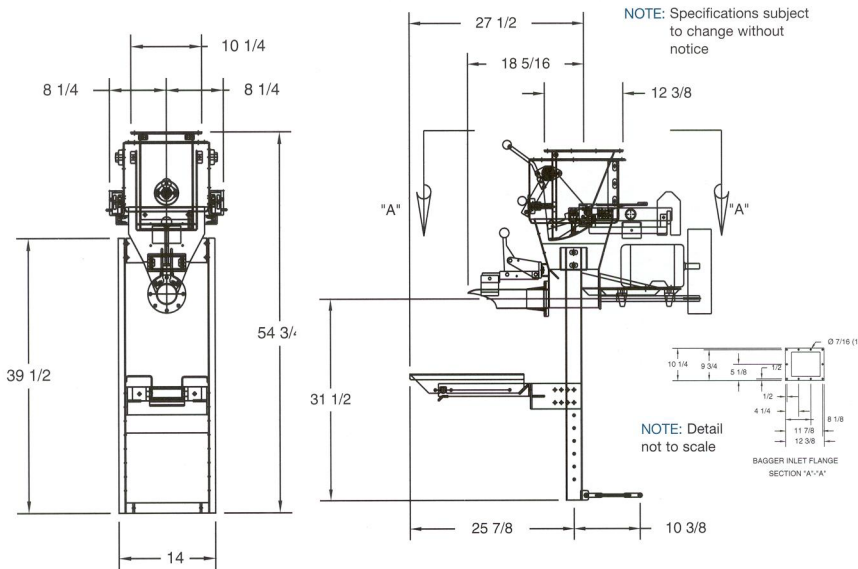

STANDARD SPECIFICATIONS:

- Rugged heavy duty mild steel construction
- Industrial rust resistant primer with enamel finish
- Scalebeam mechanical weighing
- 3/4 hp, TEFC motor, turning auger at 900 rpm
- Start-stop switch mounted on manual bag clamps
- Large 3 cubic foot surge hopper with mounting stand and casters

NOTE: testing may be required to determine obtainable speeds and accuracies on your product.

OPTIONS

- Stainless steel on contacting surfaces (t304)
- Two part chemical resistant stainless steel paint
- Hard facing on auger for abrasive materials
- Foot pedal actuator with auto start
- Air powered control circuit operating bag clamps and catch gate
- Nema 9 explosion proof electric
- Nema 4 water tight electric
- High corrosive environment protective package includes stainless steel fasteners, pvc fittings, phenolic bushings, anodized cylinders, etc
- UTILITY REQUIREMENTS: 110 volts, 60 hz – nema 12 (std)
- SHIPPING WEIGHT: 750 lbs
- CRATE DIMENSIONS: 4 ft w x 8 ft l x 4 ft h